

HQ68 拖链—安装尺寸及技术参数

HQ68 Cable Chain—Installation Dimensions and Technical Parameters

架空长度

Unsupported length

- L_G = 直线架空长度
- L_A = 安全塌架架空长度
- L_G = Unsupported with straight upper run
- L_A = Unsupported with permitted sag

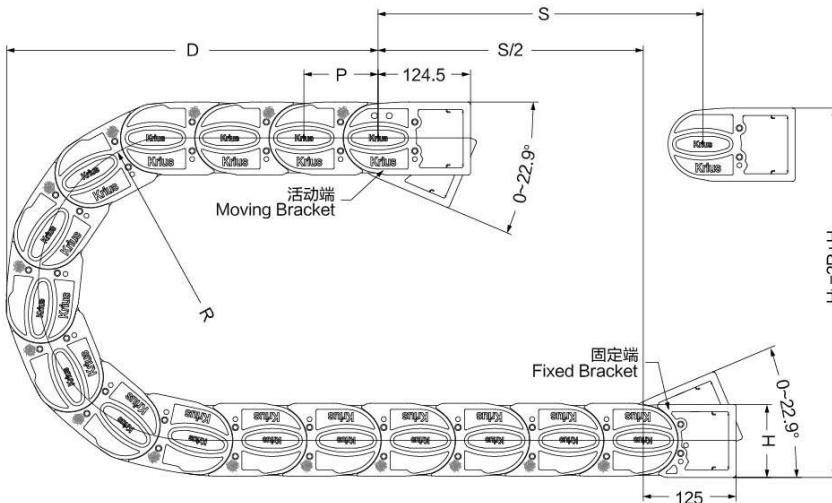
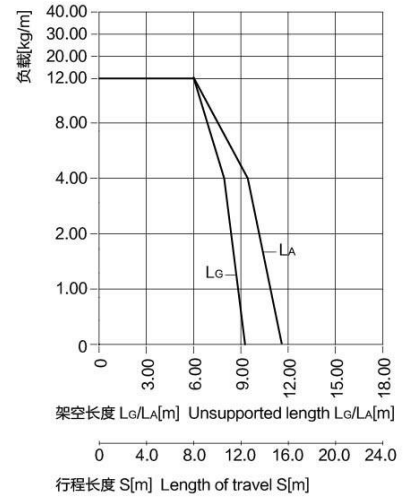
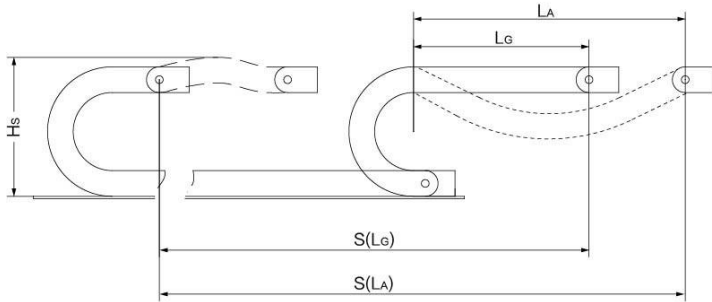

- S = 行程长度
- R = 弯曲半径
- P = 节距
- L = 拖链长度
- N = 每米链节数
- H_L = 理论安装高度
- H_s = 实际安装高度
- D = 拖链退极限位置时的最小距离
- K = $\pi \cdot R + 2P$
- * K值可在科瑞斯相关表格中直接查询
- S = Length of travel
- R = Bending Radius
- P = Pitch
- L = Length of chain
- N = Links per meter
- H_L = Nominal clearance height
- H_s = Required clearance height
- D = Overlength Energy Chain radius in final position
- K = $\pi \cdot R + 2P$
- * You can find it from below chart for more details

R	H _L	D	K	P
200(7.87)	498.5(19.63)	410(16.14)	810(32.48)	100(3.94)
250(9.84)	598.5(23.56)	510(20.08)	980(38.58)	100(3.94)
300(11.81)	698.5(27.50)	610(24.02)	1140(44.88)	100(3.94)
400(15.75)	898.5(35.37)	810(31.89)	1455(57.28)	100(3.94)
500(19.69)	1098.5(43.25)	1010(39.76)	1765(69.49)	100(3.94)

实际安装高度: $H_s = H_L + 95\text{mm}$
 拖链长度: $L = S/2 + K$
 每米链节数: $N = 10$ (1000mm)

The required clearance height: $H_s = H_L + 3.74\text{in.}$
 Chain length: $L = S/2 + K$
 Links per meter: $N = 10$ (39.37 in.)

技术参数 Technical Parameters		
速度/加速度 L_G	Speed/acceleration L_G	max.25[m/s]/max.205[m/s ²]
速度/加速度 L_A	Speed/acceleration L_A	max.5[m/s]/max.8[m/s ²]
滑行速度/加速度	Gliding speed/acceleration	max.5[m/s]/max.12[m/s ²]
材料—允许温度 °C	Material—permitted temperature	igumid G/—40°C至+125°C
阻燃等级, igumid G	Flammability Class, igumid G	VDE 0304 IIC UL94 V2



HQ68 拖链
HQ68 Cable Chain

HQ68 拖链-产品规格范围 HQ68 Cable Chain-Product specifications

HQ68拖链-内外侧可开 HQ68 Cable Chain-Inner and outer can be opened

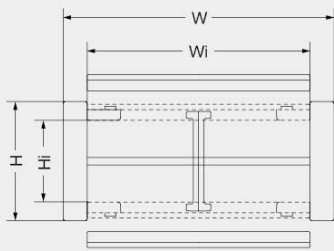

产品代码结构
Part Number Structure

HQ68100*R*L*n

- 数量 (Quantity)
- 拖链长度 (Length of Cable chains)
- 弯曲半径 (Bending Radius)
- 内宽 (Inner Width)
- 型号 (Type)

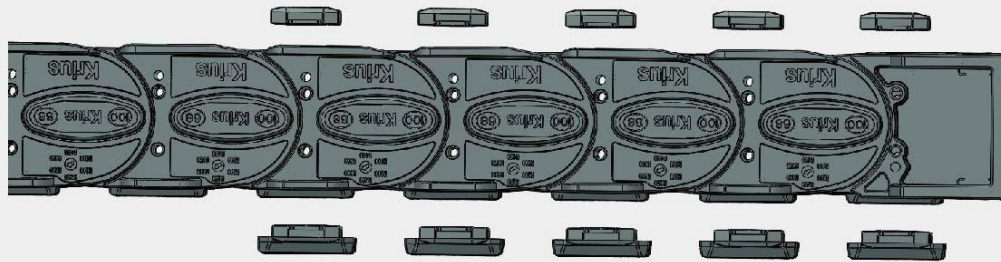

型号 Type	弯曲半径<R> Bending radius	内高<Hi> Inner height	内宽<Wi> Inner width	外高<H> Outer height	外宽<W> Outer Width	重量<G> Weight	备注 Remark
	mm(in.)	mm(in.)	mm(in.)	mm(in.)	mm(in.)	kg/m(ibs/ft)	
HQ68100		68(2.68)	100.2(3.94)	98.5(3.88)	143.4(5.64)	4.74(3.22)	
HQ68125			125.2(4.93)		168.4(6.63)	4.85(3.30)	
HQ68150			150.2(5.91)		193.4(7.62)	5.00(3.40)	
HQ68200			200.2(7.88)		243.4(9.58)	5.28(3.59)	
HQ68250			250.2(9.85)		293.4(11.55)	5.52(3.75)	
HQ68300			300.2(11.82)		343.4(13.52)	5.82(3.96)	
HQ68350			350.2(13.79)		393.4(15.49)	6.16(4.19)	
HQ68400			400.2(15.76)		443.4(17.46)	6.36(4.32)	

订货范例
Order details

HQ68100 * R200 * 1000mm * 2

R	Hi	D	K	P
200(7.87)	498.5(19.63)	410(16.14)	810(32.48)	100(3.94)
250(9.84)	598.5(23.56)	510(20.08)	980(38.58)	100(3.94)
300(11.81)	698.5(27.50)	610(24.02)	1140(44.88)	100(3.94)
400(15.75)	898.5(35.37)	810(31.89)	1455(57.28)	100(3.94)
500(19.69)	1098.5(43.25)	1010(39.76)	1765(69.49)	100(3.94)

HQ68 拖链-拖链接头 HQ68 Cable Chain-Mounting Bracket

塑料接头或钢制接头，分体式 Plastic or Steel Mounting Bracket, Splited structure

- 双侧独立式塑料接头或钢制接头
 - 两端接头均可活动
 - 耐腐蚀 & 耐摩擦
 - 可提供预装配形式
 - 可实现内外连接
- Independent Plastic or Steel mounting bracket on the two end
 - Moved connectors on both sides
 - Anti-corrosion, Rub-resistance
 - Available preassembly form
 - Can realize the internal and external connections

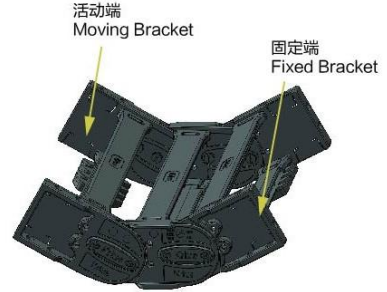

可选配的接头安装方式 Available installation methods

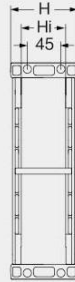
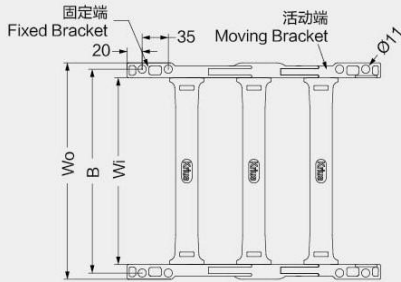
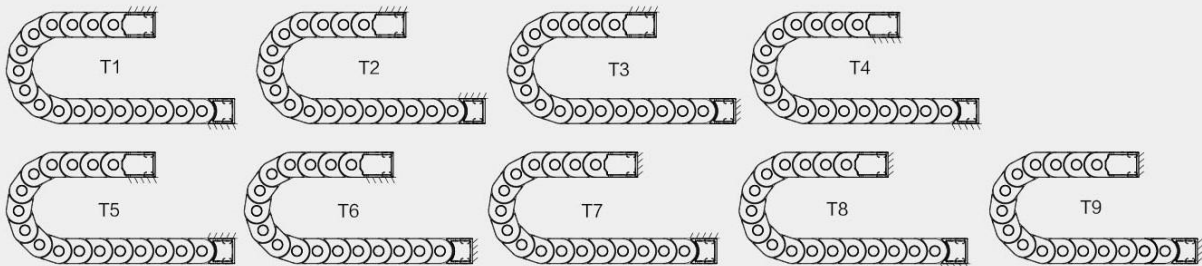

HQ68100/HQ68125
HQ68150/HQ68200
HQ68250/HQ68300
HQ68350/HQ68400

拖链型号 Type	拖链编码 Code	其他编码 Other Code		Wo尺寸 Dimension Wo mm(in.)	B尺寸 Dimension B mm(in.)
HQ68100	11200			143.4 (5.64)	123.2(4.85)
HQ68125	11255			168.4 (6.63)	148.2(5.83)
HQ68150	11201	接头 Mounting Bracket	14133	193.4 (7.62)	173.2(6.82)
HQ68200	11191	主体 Main Body Code	14134	243.4 (9.58)	223.2(8.79)
HQ68250	11202		固定片 Fixed Plate 11193	293.4 (11.55)	273.2(10.76)
HQ68300	11203		耐磨片 Anti-friction part 11194	343.4 (13.52)	323.2(12.72)
HQ68350	11204	隔离片 Separator	11192	393.4 (15.49)	373.2(14.69)
HQ68400	11205			443.4 (17.46)	423.2(16.66)

产品代码结构 Part Number Structure

HQ68100*B*T1



- HQ68100*B*T1*n 两端接头
On both brackets
- HQ68100*f*T1*n 固定端接头
Fixed bracket
- HQ68100*m*T1*n 移动端接头
Moving bracket

★ 每款拖链的接头都有所不同，订购时如有任何疑问，请及时咨询科瑞斯。
Every bracket is different, please contact us if you have any question.

HQ68 Cable Chain
拖链

HQ68 拖链-隔离片 HQ68 Cable Chain-Separator

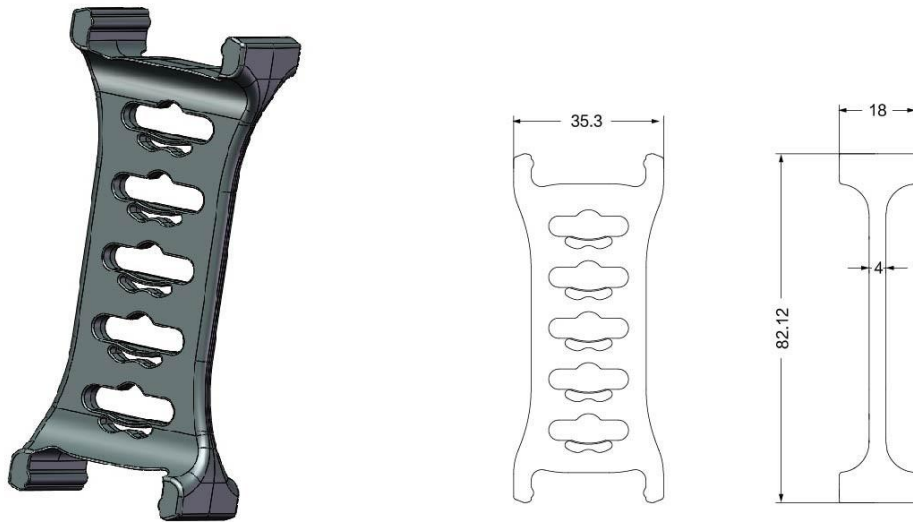

HQ68拖链隔离片编码：11192
The separator No. for HQ68: 11192

- 本款拖链标配隔离片为竖隔片，可以实现垂直分隔，也可订制铝杆作为横隔片，实现水平分隔
- 竖隔片的数量可以根据客户的实际需求进行配备，可以每隔一个链节装一个，也可以每隔一个链节装几个，客户可任意配备
- 竖隔片安装完成后，可以根据线缆排布进行滑动
- The standard separator is vertical direction which can make the vertical division, and also we can customize horizontal Al separator for horizontal division
- Vertical separators can be placed into each link or different quantity links, it can be customized
- Separator can be moved for different cable